

# Standalone Photovoltaic System with Maximum Power Point Tracking: Modeling and Simulation

Hanane Yatimi<sup>#1</sup>, Elhassan Aroudam<sup>#2</sup>

<sup>#</sup>*Modeling and Simulation of Mechanical System Team, Physics Department, Faculty of Sciences, Abdelmalek Essaadi University, Sebta Ave., Mhannech II BP 2121, Tetouan, 93002, Morocco*

<sup>1</sup>yatimi.hanane@gmail.com

**Abstract** — According to the nonlinear power-voltage characteristic of the photovoltaic (PV) solar cell, we need to track maximum output power instantly. The aim of this paper is uphold the PV cell operating at its maximum power point (MPP) and then make full utilization of its output power. For this reason, the maximum power point tracking (MPPT) incremental conductance (IC) is proposed to draw peak power from the PV cell to maximize the produced energy under varying meteorological conditions. The performance of the proposed technique has been analyzed through computer simulations to illustrate the validity of the designed method under various climatic conditions.

**Keywords**— PV storage system, DC/DC boost converter, Storage battery, MPPT, Incremental Conductance (IC), Modeling, Simulation.

## I. INTRODUCTION

The demand of energy increases these last year's considerably, in addition the conventional energy sources are dwindling and have a negative impact on the environmental such as greenhouse gases effect and also endangering human health and natural life [1]. In order to preserve our natural living spaces and protect their resilience, a renewed compatibility would require a suitable form of alternatives energy sources mainly renewable energy sources that should be independent and easily accessible [1]. The Renewable energy has an advance all over the world in the environment protection, since; it is clean, operating silently, long life time, low maintenance and absence of fuel cost and inexhaustible, in particular photovoltaic solar energy. Photovoltaic systems have been widely utilized in various applications, such as battery charging, water pumping [2], home power supply etc., to convert the solar energy to electrical energy through the semiconductor devices called photovoltaic cells based on photovoltaic effect [3].

In photovoltaic power systems, maximum power point tracking (MPPT) is essential because it takes full advantage of the available solar energy. And since the output characteristics of PV cell is nonlinear and changes with temperature and solar irradiance, its maximum power point (MPP) is not constant. Under each condition PV module has a point at which it can produce its MPP. Therefore, MPPT techniques can be used to uphold the PV module operating at its MPP and then to increase the PV system efficiency.

Many MPPT techniques have been proposed in the literature. Examples are the Perturb and Observe (P&O)

method [4], the Incremental Conductance (IC) method [5], the Fuzzy Logic method [6], the Artificial Neural Network method [7], the genetic algorithm [8], etc.. These techniques vary between them in many aspects, including simplicity, convergence speed, hardware implementation, sensors required, and cost. The P&O is the most widely used algorithm due to the simplicity of structure and the ease of implementation. But it has limitations that reduce efficiency of MPPT. In fact, it can work well when the solar irradiance and the temperature do not vary quickly with time. However, it can't track the MPP quickly and the output power is oscillating around the MPP. The IC method has better performance than the P&O method. The main advantage of IC method is that it can offer good performance under rapidly changing atmospheric conditions in addition to its ability to achieve lower oscillation around MPP than P&O method, but the oscillations around the MPP still exists causing the energy losses.

The reminder paper is structured as follow: the PV storage system description and modeling are presented in Section 2. Section 3 describes the IC MPPT technique. In Section 4, the analysis based on the simulation results, using Matlab/Simulink software is conducted. Finally, brief conclusions are drawn.

## II. PHOTOVOLTAIC STORAGE SYSTEM MODELING

The complete studied system is schematically shown in Fig. 1. In our analysis, we consider a PV module supplying a DC load, e.g. a battery through an adaptation stage considered by boost converter, driven by a MPPT assuming the maximum efficiency for the energy transfer.



Fig. 1 Block diagram of photovoltaic system.

### A. Modeling and Characteristic of PV Module

As the PV module is composed of groups of cells associated in series and/or parallel, its model is based on that of a PV cell. The equivalent circuit of the PV cell is shown in Fig. 2 [9]. Series resistance  $R_s$  and Parallel  $R_p$  are added to the model to take into account the dissipative phenomena at the cell (internal losses).

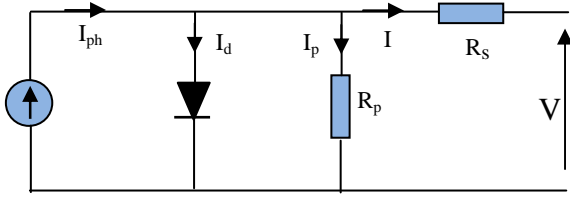

Fig. 2 Equivalent electrical circuit of PV cell.

The characteristic equation for the current and voltage of PV cell is given as follows [9]:

$$I_p = I_{ph} - I_d - I_{sh} \quad (1)$$

$$I_p = I_{ph} - I_0 \left[ \exp \left( \left( \frac{q}{aKT} \right) (V_p + I_p R_s) \right) - 1 \right] - \left( \frac{V_p + I_p R_s}{R_p} \right) \quad (2)$$

Where:  $V_p$  is the output voltage of the PV cell (V).  $I_p$  is the output current of the PV cell (A).  $T$  is the cell temperature (K).  $a$  is the diode ideality factor.  $q$  is the electron charge ( $1.60217 \cdot 10^{-19}$  C).  $K$  is the Boltzmann constant ( $1.38 \cdot 10^{-23}$  J/K).  $R_s$  is the series resistance of cell ( $\Omega$ ).  $R_p$  is the parallel resistance of cell ( $\Omega$ ).  $I_{ph}$  is the generated photocurrent (A), it depends mainly on the radiation and cell's temperature, which is expressed as:

$$I_{ph} = \left[ I_{SCR} + K_i (T - T_r) \right] \left( \frac{G}{1000} \right) \quad (3)$$

Where:  $I_{SCR}$  is the short-circuit current at reference condition (A).  $G$  is the solar irradiance ( $W/m^2$ ).  $K_i$  is the short-circuit temperature coefficient.  $T_r$  is the reference temperature (K).  $I_0$  is the reverse saturation current of diode (A), it is influenced by the temperature according to the following equation:

$$I_0 = I_{rs} \left[ \frac{T}{T_r} \right]^3 \exp \left[ \left( \frac{qE_{g0}}{aK} \right) \left( \frac{1}{T_r} - \frac{1}{T} \right) \right] \quad (4)$$

Where:  $I_{rs}$  is the saturation current at reference temperature (A),  $E_{g0}$  is the silicon band gap.

The PV module mathematical model is represented by the equation:

$$I = N_p I_{ph} - N_p I_0 \left[ \exp \left( \left( \frac{q}{akT} \right) \left( \frac{V}{N_s} + I \frac{R_s}{N_p} \right) \right) - 1 \right] - \frac{N_p}{R_p} \left( \frac{V}{N_s} + I \frac{R_s}{N_p} \right) \quad (5)$$

Where:  $N_s$ : series PV cell per module,  $N_p$ : parallel PV cell per module.

Fig. 3, [10] shows the behavior of a PV module under the effect of solar irradiance variation and constant temperature, considering an example of one month of winter (December).

From these curves, it can be seen that solar irradiance has a significant effect on the short-circuit current, while the effect on the voltage in open circuit is quite low. Regarding the power, as seen in the figure, it increases during the first hours of the day and gradually decreases and we can clearly notice the existence of the maximum on the power curves, corresponding to the Maximum Power Point  $P_{MPP}$ .

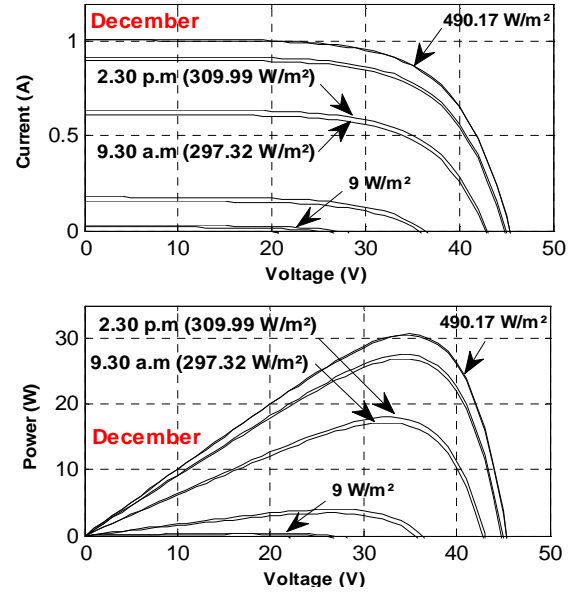
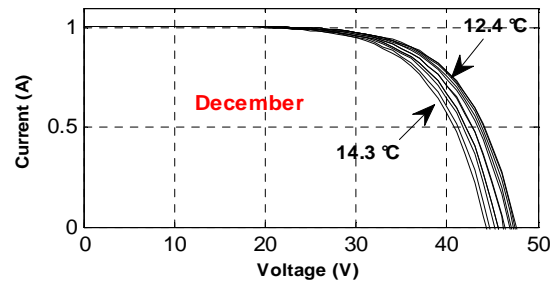

Fig. 3  $I$ - $V$  and  $P$ - $V$  Characteristics at Constant Temperature and Variable Solar irradiance for the typical clear day of one month of winter season (December)-Tetouan [10]

Fig. 4, [10] shows the behavior of a PV module under the effect of temperature variation and constant solar irradiance, considering an example of one month of winter (December). From these curves, we can clearly detect that the temperature has a very important effect on the open circuit voltage and a no remarkable effect on both the short circuit current and the power of the module.

To conclude, the more solar irradiance is high, the more PV module generates power. The more temperature is low the more PV module generates power. These figures are using the real meteorological data locally measured at regular intervals (1 hour) throughout the typical clear day of December in Northern Morocco (Tetouan). To sum up, the use of the MPPT techniques to extract the maximum available power at any changes is primordial



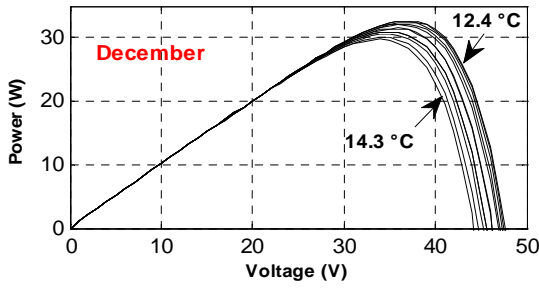

Fig. 4 I-V and P-V characteristics at constant solar irradiance and variable temperature for the typical clear day of one month of winter season (December)-Tetouan [10]

### B. DC-DC converter and Battery Model

A DC/DC boost converter also called step-up converter is a DC to DC power electronic converter steps up voltage (while stepping down current) from its input (PV module) to its output (battery), in order to force the PV module to operate at the MPP. The used converter is composed of two semiconductor switches (a diode and a MOSFET transistor), an inductor, an input and output capacitors to limit respectively the ripple of the input voltage  $V$  and the output voltage  $V_o$ , and one energy storage element. The battery is represented by a simple voltage source  $V_b$  in series with a resistance  $R_b$  (internal resistance of the battery (Fig. 5).

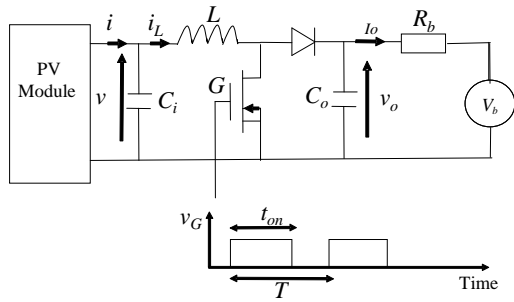

Fig. 5 Boost converter coupling the PV module to the battery.

It is periodically controlled with a modulation period  $T$ . Over this period,  $t_{on}$  called the closing time and  $t_{off}$  for the opening time, we have:  $T = t_{on} + t_{off}$ . The duty cycle of the converter is defined as:  $\alpha = t_{on}/T$ .

The switches are alternatively opened and closed. For  $t \in [0, \alpha T]$ , as long as transistor is ON, the diode is OFF, being reversed biased. The input voltage, applied directly to inductance  $L$  which stores energy, determines a linear rising current. By applying Kirchhoff's theorem, we get:

$$\begin{cases} C_i \frac{dv}{dt} = i - i_L \\ L \frac{di_L}{dt} = v \\ C_o \frac{dv_o}{dt} = -i_o \end{cases} \quad (6)$$

For  $t \in [\alpha T, T]$ , when the transistor on OFF, the voltage across the inductor will change the polarity and the diode will switch in ON state. By applying Kirchhoff's theorem, we get:

$$\begin{cases} C_i \frac{dv}{dt} = i - i_L \\ L \frac{di_L}{dt} = v - v_o \\ C_o \frac{dv_o}{dt} = i_L - i_o \end{cases} \quad (7)$$

Considering the periods of open and closed circuit operation, the state equations of the boost converter average model [11] operating in continuous conduction mode (the current through the output inductor never reaches zero), by applying Kirchhoff's theorem are:

$$\begin{cases} C_i \frac{dv}{dt} = i - i_L \\ L \frac{di_L}{dt} = v - (1 - \alpha)v_o \\ C_o \frac{dv_o}{dt} = -i_o + (1 - \alpha)i_L \end{cases} \quad (8)$$

Where:

$$v_o = v_b + R_b i_o \quad (9)$$

$i$  and  $v$  are the output current and voltage of the PV module,  $i_L$  is the inductor current,  $i_b$  and  $v_b$  are the average states of respectively the battery current and the battery voltage,  $v_o$  is the DC/DC converter output voltage,  $\alpha$  is the duty cycle, which represents the control input,  $L$  is the DC/DC converter inductance and  $C_i$  and  $C_b$  are respectively the input capacitor and the output capacitor of the converter.

### III. INCREMENTAL CONDUCTANCE MPPT TECHNIQUE

The output power of the PV module changes with change in direction of the sun, which means, change in solar irradiance level and change in temperature. There is a single maximum power point (MPP) in the PV characteristics of the PV module (Fig. 6) for particular operating condition. The process of operating of the PV module at this condition is called as maximum power point tracking (MPPT). Maximization of PV power improves the utilization of the PV module [12]. The incremental conductance method has been proposed in 1993 and expected to overcome the disadvantage of P&O method which fails to track the peak power point under fast varying conditions. This method requires the values of the PV module output current and voltage to calculate the conductance and the incremental conductance. The output

power of PV module can be expressed as:  $P=V \times I$ . Then the derivative of product yields:

$$\frac{dP}{dV} = \frac{d(V.I)}{dV} = I + V \cdot \frac{dI}{dV} \quad (10)$$

Where: P, V and I are the PV module output power, voltage and current, respectively. The task of this technique is to track the voltage operating point which conductance is equal to incremental conductance.

As shown in Fig. 6, the slope of the PV module power-voltage curve equals to zero at the MPP, increasing on the left of the MPP and decreasing on the right side of the MPP, which is expressed by the following equations:

$$\begin{cases} \frac{dP}{dV} = 0 \Rightarrow \frac{dI}{dV} = -\frac{I}{V}, \text{ at MPPT} \\ \frac{dP}{dV} > 0 \Rightarrow \frac{dI}{dV} > -\frac{I}{V}, \text{ left of MPPT} \\ \frac{dP}{dV} < 0 \Rightarrow \frac{dI}{dV} < -\frac{I}{V}, \text{ right of MPPT} \end{cases} \quad (11)$$

The equations (11) are used to determine the direction in which a perturbation must occur to shift the operating point toward the MPP and the perturbation is repeated until  $\frac{dP}{dV}=0$ .

The flowchart of the IC method is shown in Fig. 7.

The operating point tracks MPP by comparing the immediate conductance ( $I/V$ ) to the Incremental Conductance ( $dI/dV$ ) as explained in Fig. 7. Once, the MPP is reached, the operation of the PV module is maintained at this point unless a change in  $dI$  is noticed, indicating a change in meteorological conditions.

#### IV. SIMULATION RESULTS AND DISCUSSION

The PV module model, the average boost converter model and the proposed MPPT method are implemented in Matlab/Simulink. In this study, SW 255 Poly PV module manufactured by Solar Word has been selected as PV power source. The used PV storage system to validate the proposed MPPT technique has the parameters summarizes in the table 1.

The proposed MPPT method is evaluated from two aspects: PV response to solar irradiance and temperature variations. In each figure, two different values of solar irradiance and temperature are presented for comparison in order to show the effectiveness of the IC method.

##### A. Theoretical results

For different values of solar irradiance G and temperature T, the computation of the theoretical optimum values of PV current  $i$ , PV voltage  $v$ , PV power  $p$ , duty cycle  $\alpha$  and output voltage  $v_o$ , is assembled in table 2.

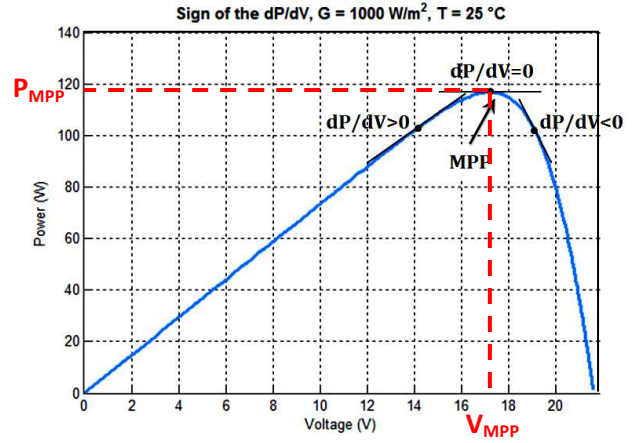

Fig. 6 Sign of the  $dP/dV$  at different positions on the P-V characteristic curve of a PV module.

TABLE I  
SIMULATION PARAMETERS

Parameter	Name	Value
<b>PV module SW 255 Poly-Datasheet Parameters [13]</b>		
$P_{max}$	Maximum power	255 W
$V_{mp}$	Voltage at maximum power	30.9 V
$I_{mp}$	Current at maximum power	8.32 A
$V_{oc}$	Open circuit voltage	38 V
$V_{sc}$	Short circuit current	8.88 A
$K_i$	Temperature coefficient of $I_{sc}$	0.051 %/K
$N_s$	Number of cells per module	60
$T_r$	Reference temperature	298.15 K (25°C)
E	Reference solar irradiance	1000 W/m <sup>2</sup>
<b>PV module SW 255 Poly-Extracted Parameters</b>		
$R_s$	Series resistance	0.2038 $\Omega$
$R_p$	Parallel resistance	6500 $\Omega$
a	Ideality factor	1.2646
$I_{SCR}$	Short circuit current at STC	8.8803 A
$I_{rs}$	Saturation current at $T_r$	$3.0588 \cdot 10^{-8}$ A
<b>DC-DC Boost Converter</b>		
L	Inductance	3.5 mH
$C_i$	Input capacitor	4.7 mF
$C_o$	Output capacitor	0.47 mF
<b>Battery</b>		
$V_b$	Battery voltage	48 V
$R_b$	Battery resistance	2 $\Omega$

##### B. Simulation results

A simulation study was made to illustrate the response of the system to solar irradiance G and module temperature T variation. For this purpose, the solar irradiance G and the temperature T, which are initially at 1000W/m<sup>2</sup> and 298.15K (25°C), are respectively switched at 1s and 2s to 600W/m<sup>2</sup> and 323.15K (50°C) as shown in the simulation figures Fig. 8 and Fig. 9.

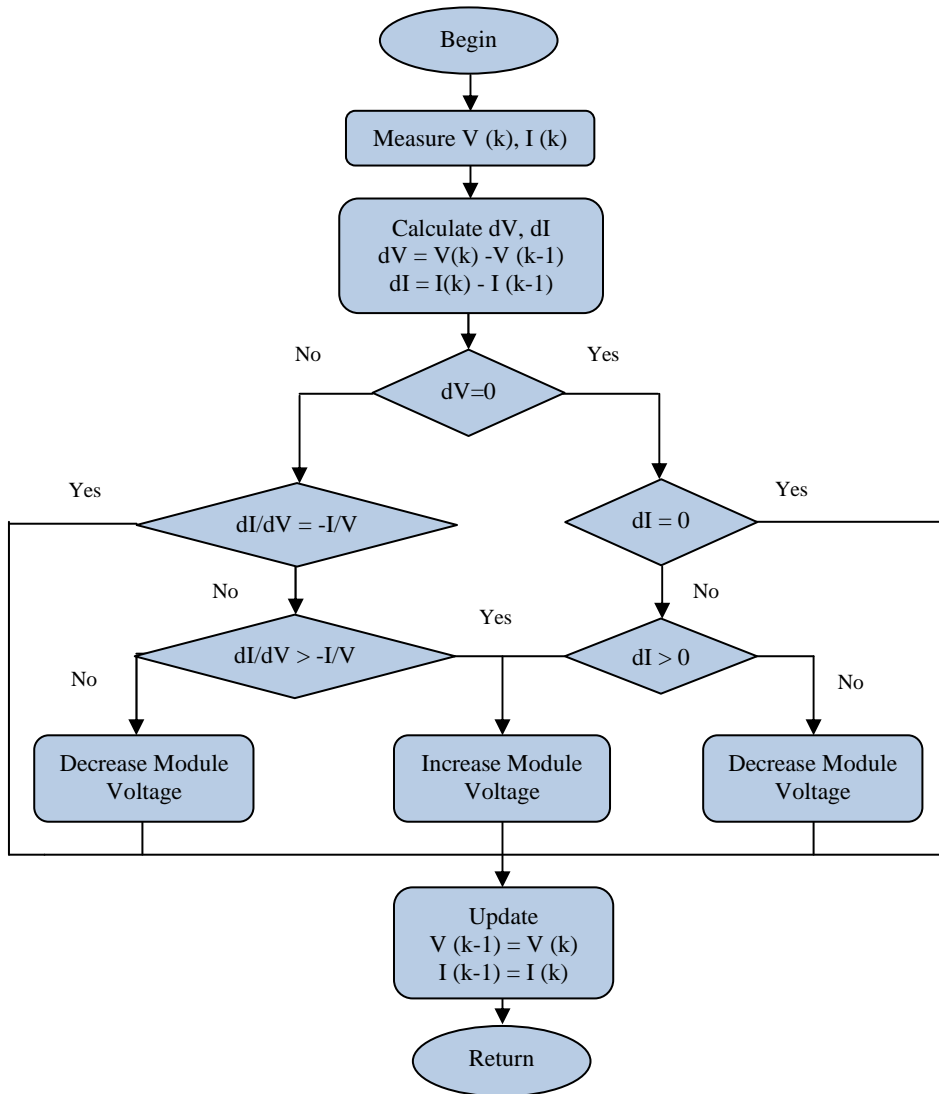

Fig. 7 Flow chart for IC technique.

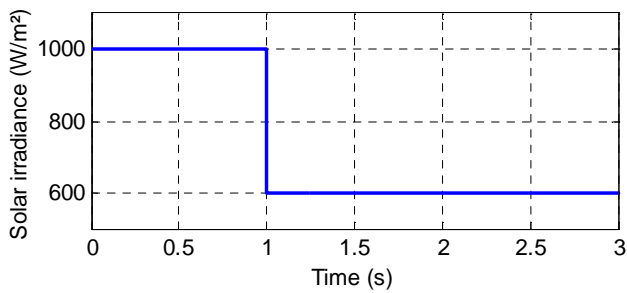

Fig. 8 Change of solar irradiance.

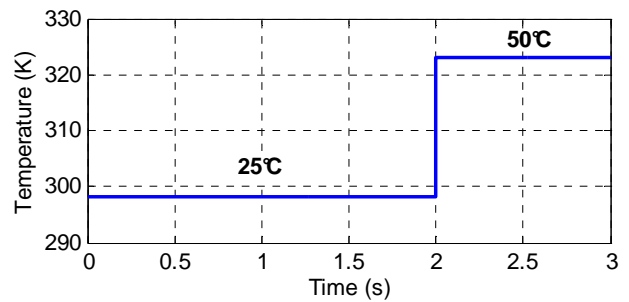

Fig. 9 Change of temperature.

TABLE 2  
THEORETICAL RESULTS FOR GIVEN SOLAR IRRADIANCE AND TEMPERATURE.

Value of G(W/m²)/T(K)	I (A)	V (V)	P (W)	$\alpha$	$V_o$ (V)
1000/298.15 K (25°C)	8.3200	30.9171	257.2313	0.4578	57.0222
600/298.15 (25°C)	4.9940	30.5759	152.6949	0.4305	53.6882
600/323.15 (50°C)	4.9372	27.4711	135.6315	0.4827	53.1078

Fig. 10, Fig. 11, Fig. 12, Fig. 13 and Fig. 14 show respectively the good convergence between the PV current, the voltage, the power of the PV module, the duty cycle control of the DC-DC converter and the system output voltage with the theoretical results, as a result the system operates at its MPP after a smooth transient response. It is concluded from the simulations that, when the solar irradiance and temperature varies, the duty cycle of the boost converter  $\alpha$  is judiciously adjusted to its desired value (Fig. 13), which forces the PV module voltage to follow its optimal value (Fig. 11). Consequently, the PV module power reached its maximal value (Fig. 12).

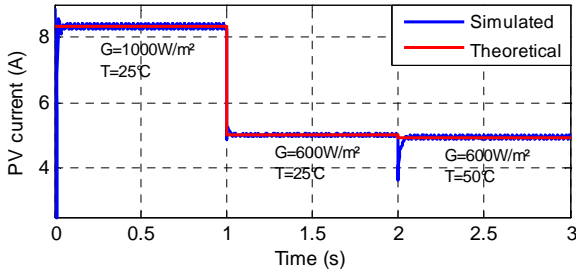

Fig. 10 PV current.

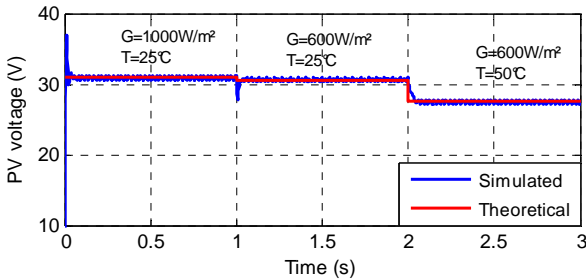

Fig. 11 PV voltage.

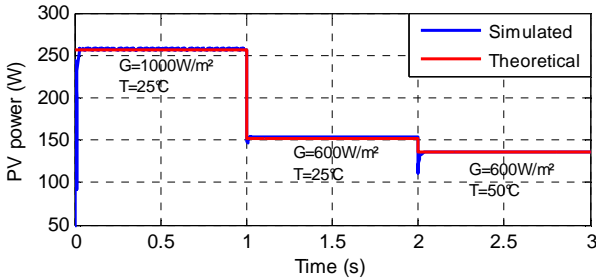

Fig. 12 PV power.

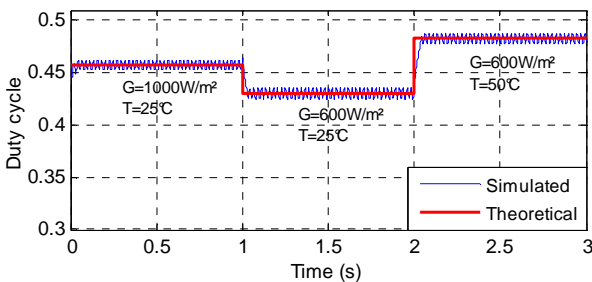

Fig. 13 Duty cycle ( $\alpha$ ).

## V. CONCLUSIONS

In this paper we applied the IC technique to a stand-alone PV system with battery storage. DC/DC boost converter

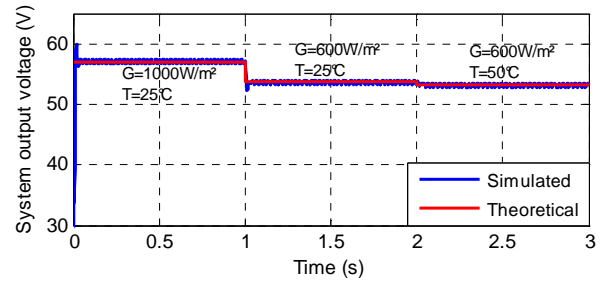

Fig. 14 System output voltage.

operating in continuous conduction mode is used to supply the needed power to the battery. The proposed system was simulated in Matlab/Simulink software. Five parameters of the polycrystalline PV module “SW 255 Poly” are extracted and used to calculate the optimal values, for different solar irradiance and temperature levels, of all of PV current, voltage and power, duty cycle of the Boost converter and the system output voltage. As a result the system operates at its MPP.

## REFERENCES

- [1] Hanane Yatimi, Elhassan Aroudam, *Assessment and control of a photovoltaic energy storage system based on the robust sliding mode MPPT controller*. Sol. Energy. 139, 557–568, 2016.
- [2] Nejib Hamrouni, Moncef Jraidi, Adnene Cherif, *Theoretical and experimental analysis of the behavior of a photovoltaic pumping system*. Sol. Energy. 83, 1335-1344, 2009.
- [3] R. Boukenoui, H. Salhi, R. Bradai, A. Mellit, *A new intelligent MPPT method for stand-alone photovoltaic systems operating under fast transient variations of shading patterns*. Sol. Energy. 124, 124-142, 2016.
- [4] N. Femia, G. Petrone, G. Spagnuolo and M. Vitelli, *Optimization of perturb and observe maximum power point tracking method*. IEEE Trans. Power Electron.. 20 (4), 963–73, 2005.
- [5] Safari A, Mekhilef S, *Simulation and hardware implementation of incremental conductance MPPT with direct control method using Cuk converter*. IEEE Trans. Ind. Electron.. 58(4), 1154–61, 2011.
- [6] Kyoungsoo R, Rahman S, *Two-loop controller for maximizing performance of a grid-connected photovoltaic-fuel cell hybrid power plant*. IEEE Trans Energy Conver. 13(3), 276–81, 1998.
- [7] Anil K. Rai, N. D. Kaushika, B. Singh and N. Agarwal, *Simulation model of ANN based maximum power point tracking controller for solar PV system*. Sol Energy Mater Sol Cells. 95(2), 773–8, 2011.
- [8] A. Messai, A. Mellit, A., Guessoum and S. A. Kalogirou, *Maximum power point tracking using a GA optimized fuzzy logic controller and its FPGA implementation*. Sol. Energy. 85, 265–277, 2011.
- [9] D. Picault, B. Raison, S. Bacha, J. de la Casa and J. Aguilera, *Forecasting photovoltaic array power production subject to mismatch losses*. Sol. Energy. 84, 1301–1309, 2010.
- [10] H. Yatimi and E. Aroudam, *Evaluation of the Characteristics of the PV Module Considering Effects of Real Climatic Conditions*. In: Ali Sayigh Editor. Renewable Energy in the Service of Mankind Vol II. Springer International Publishing Switzerland, United Kingdom, pp. 457-467, 2016.
- [11] J. Chen, R. Erickson, and D. Maksimovic, *Averaged Switch Modeling of Boundary Conduction Mode Dc-to-Dc Converters*. IECON'01: The 27th Annual Conference of the IEEE Ind. Electronic. Society, Denver, Colorado, USA, 844-849. DOI 10.1109/IECON.2001.975867, 2001.
- [12] Roberto F. Coelho, F. Concer and Denizar C. Martins, *A Study of Basic DC-DC Converters Applied in Maximum Power Point Tracking*. Proceedings of IEEE Conference, ISBN: 978- 1-4244-3370-4, pp. 673-677, 2009.
- [13] The datasheet of module SW 255 Mono. Available online: [www.solarworld.com](http://www.solarworld.com). Consulted : November 2014.